



A Parallax-Free No-Glare CRT for -hp- Oscilloscopes

PARALLAX errors and annoying reflections and glare have been overcome through the development of a new series of cathode ray tubes for Hewlett-Packard oscilloscopes. In the new crt's, the graticule is located on the inside surface of the front of the tube in intimate contact with the phosphor screen. Since the trace and the graticule are thus located in the same plane, there can be no parallax error, regardless of viewing angle. Also, reflections and glare have been eliminated in the new crt's by means of a special treatment given to the front surface of the tube.

SEE ALSO
"A New 450 kc
Oscilloscope", p. 3

PARALLAX ERRORS IN OSCILLOSCOPES

In a conventional oscilloscope crt, the trace appears in the plane of the phosphor on the inside surface of the glass faceplate that forms the front of the tube. The graticule or scale is generally scribed on a plastic disc which may be placed in contact with the faceplate. However, in many applications a filter is placed between the faceplate and the graticule. The trace is thus separated from the scale by the thickness of the faceplate plus the thickness of any filter used. When making measurements from the trace, an error due to parallax will occur whenever a line from the eye or camera lens to the desired point on the trace is not perpendicular to the plane of the graticule.

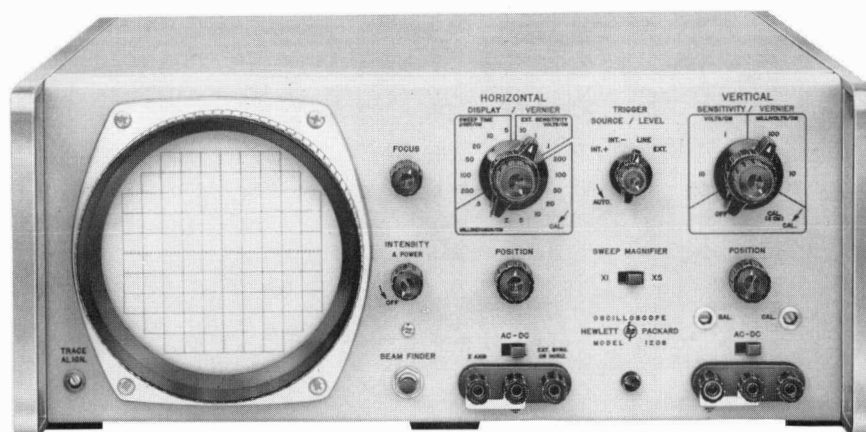

Fig. 1. Internal-graticule cathode-ray tube as used in the new -hp- DC - 450 kc oscilloscope (see p. 3). Locating the graticule on inside of front of tube removes parallax error previously existing with crt's using separate

graticule. Scope trace can thus be read accurately from any viewing angle or by two viewers. New tube also has specially-processed front surface that essentially eliminates reflections, making viewing easier.

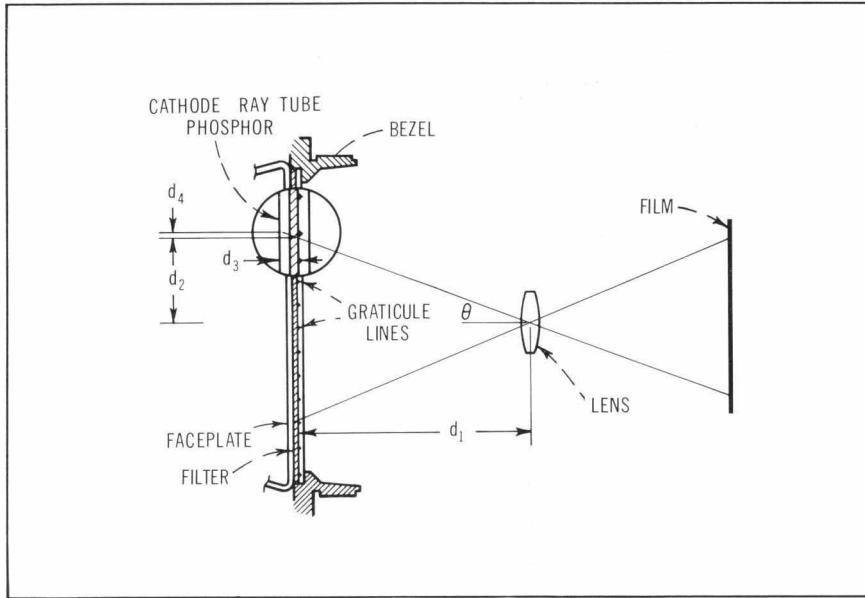

Fig. 2. Diagram illustrating source of parallax error d_4 in oscilloscopes. Since phosphor and graticule in new crt are located in same plane, parallax error is eliminated.

The geometry associated with crt parallax is illustrated in Fig. 2. The parallax error, d_4 , can be calculated by using the following ratios:

$$\frac{d_2}{d_1} = \tan \theta = \frac{d_4}{d_3}$$

$$d_4 = \frac{d_2 d_3}{d_1}$$

In oscilloscope photography, the camera lens behaves like a single eye viewing the trace at a fixed distance from the crt. When using the -hp- Model 196A Camera, this distance, d_1 , is approximately 17 cm. In a typical oscilloscope using a standard filter, d_3 is approximately 0.66 cm. Assuming a horizontal signal across the full 10 cm screen, the

parallax error from the above equation is 0.19 cm at the outer edges of the usual 10 cm wide graticule. This would lead to an error of approximately 4% full scale on a 10 cm waveform. Fig. 3 illustrates a time marker waveform photographed with a typical crt. The parallax error is quite evident, whereas in a corresponding photograph using a new internal graticule crt, no parallax error can be observed.

When vertical and horizontal accuracy specifications for oscilloscopes are reviewed, the parallax error takes on added significance. Many oscilloscopes are calibrated to $\pm 3\%$ both in sweep time accuracy

and vertical sensitivity. Parallax error, however, is not accounted for in the basic instrument specifications. As shown earlier, this can be as much as 4%, which is greater than the sum of the errors from all other causes. One widely used method of overcoming parallax error is to align the trace and graticule with the reflection of the observer's eye. At best, this method and others like it are inconvenient and time consuming procedures.

In addition to solving the problem of measurement error during routine "head-on" viewing, the new crt's also make accurate measurements possible from any position in which the screen can be seen. Thus, two viewers may simultaneously watch the trace and obtain the same results. Oscilloscope users may leave the normal viewing zone to adjust circuits or other equipment and still be confident that trace observations are accurate. With parallax eliminated, it becomes possible to mount oscilloscopes in any desired position in consoles and racks.

DEVELOPMENT OF THE NEW CRT'S

Initial efforts in developing the new crt's were devoted to the basic technique of applying the scale to the inside of the faceplate. The scale had to be applied before the phosphor screen and, hence, had to withstand the acid and caustic washes used to clean the bulb interior. It also had to withstand exposure to the caustic settling solution used in applying the phosphor, exposure to

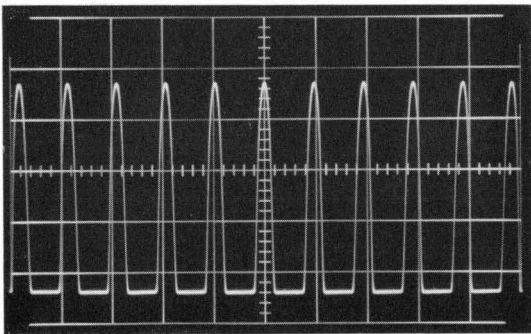

Fig. 3

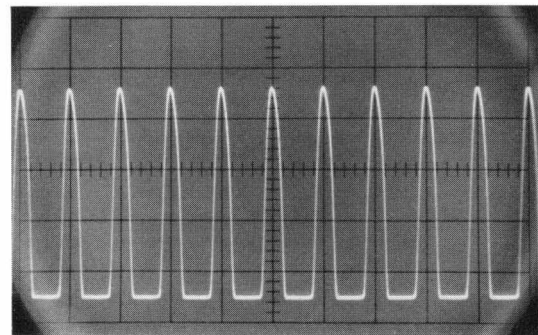

Fig. 4

Oscillograms comparing parallax error from typical crt (Fig. 3) and new internal-graticule tube (Fig. 4). Oscillograms were made by first visually aligning peaks in trace with vertical lines of

graticule, then photographing with -hp- 196A camera. In Fig. 3 parallax error displaces outer peaks about 2% at each edge, while with internal-graticule tube in Fig. 4 no error occurs.

the high temperature used in baking the bulb, and later exposure to electron beam bombardment in the evacuated crt. The material finally selected was a finely ground black glass which is applied to the flat

disc faceplate and is then bonded to the faceplate at a high temperature.

Since there is no need for a separate plastic graticule with the new crt's, it became possible to attack a second long-standing oscilloscope

viewer problem — reflection and glare from the crt. The result was a crt with a special glass disc bonded to the faceplate. The front of the disc is etched and ground, producing a surface of many minute,

A NEW DC - 450 KC OSCILLOSCOPE USING THE INTERNAL-GRATICULE CRT

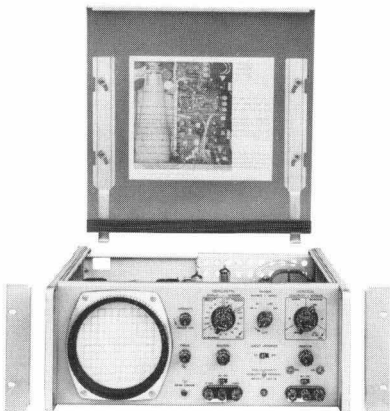

New -hp- Model 120B oscilloscope operates from dc to 450 kc with a vertical system sensitivity of 10 mv/cm. Dual-purpose cabinet can be used either in bench service or can be rack mounted using brackets supplied. Inside of instrument top cover contains large illustration locating most components and all adjustments.

The new internal-graticule cathode-ray tube described in this issue is available for any of the -hp- oscilloscopes, but it has been made standard equipment in the new -hp- Model 120B oscilloscope. This new instrument operates from dc to 450 kc and has a vertical system sensitivity of 10 millivolts/cm, characteristics that give the instrument the performance capabilities of oscilloscopes that are considerably higher in price.

As shown in the illustration, the instrument is also housed in a new style of dual-purpose cabinet that can be used either in bench service or as a rack-mounting type cabinet. Rack-mounting of the cabinet is achieved by the use of special brackets supplied with each instrument.

-hp- BEAM FINDER — AUTOMATIC BASELINE COMBINATION

The instrument also includes the -hp- "beam finder" feature in which a panel push switch will always return an off-screen trace to the screen, regardless

of the setting of the positioning controls. At the same time the switch increases the beam intensity to make the trace visible if the intensity control has been set below the visual threshold. The beam-finder switch is thus a significant convenience in making initial set-up adjustments and has proved very popular in other -hp- oscilloscopes.

Another feature which has proved popular in other -hp- oscilloscopes and is included in the new oscilloscope is the -hp- automatic baseline feature. By means of this feature a trace is automatically presented on the crt when no signal is present so that the operator always knows the location of the vertical system reference.

CRT DATA

The cathode-ray tube in the oscilloscope has the new internal graticule and is a 5-inch size which provides a full 10 x 10 cm viewing area. The tube is normally supplied with a P31 phosphor but is alternately available with a P2, P7, or P11 phosphor. It is a mono-accelerator type similar to the 5AQP — but is somewhat shorter, a factor which has permitted the overall depth of the cabinet to be held to only 16 $\frac{3}{8}$ " as an accommodation in rack mounting.

OTHER CONVENIENCES

The oscilloscope has a number of other features that give considerable convenience and flexibility in typical general-purpose work. The phase shift between the horizontal and vertical amplifiers is small up to 100 kc, permitting accurate measurements of the relative phase between two signals. An internal calibrator provides a square-wave signal which permits the amplitude calibration of the vertical amplifier to be checked merely by setting a knob. A sweep magnifier expands the portion of the sweep that occupies the center part of the crt. The cabinet is only 7 inches high and is provided with a tilt bail for maximum convenience of viewing. Spring-loaded handles are provided on either side for ease in carrying, while for rack-mount usage pressure-actuated tilting slides are available for installation in place of the handles. —Robert L. DeVries.

SPECIFICATIONS

-hp- MODEL 120B OSCILLOSCOPE

VERTICAL AMPLIFIER

Bandwidth: DC coupled: dc to 450 kc. AC coupled: 2 cps to 450 kc. Bandwidth is independent of sensitivity setting.

Sensitivity: 10 millivolts/cm to 100 volts/cm. 4 calibrated steps with attenuator accuracy of $\pm 3\%$, 10 mv/cm, 100 mv/cm, 1 v/cm, and 10 v/cm. Vernier permits continuous adjustment of sensitivity between steps and extends 10 v/cm step to at least 100 v/cm.

Internal Calibrator: Calibrating signal automatically connected to vertical amplifier for standardizing of gain, accuracy $\pm 2\%$.

Input Impedance: 1 megohm, approximately 50 pf shunt.

Balanced Input: On 10 mv/cm range. Input impedance, 2 megohms shunted by approximately 25 pf.

Common Mode Rejection: Rejection at least 40 db. Common mode signal must not exceed ± 3 volts peak.

Phase Shift: Vertical and horizontal amplifiers have same phase characteristics within $\pm 2^\circ$ to 100 kc when verniers are in CAL.

SWEEP

Sweep Range: 1 μ sec/cm to at least 0.5 sec/cm. 15 calibrated sweeps accurate to within $\pm 5\%$, in a 1, 2, 5, 10... sequence, 5 μ sec/cm to 200 millisecc/cm. Vernier permits continuous adjustment of sweep time between calibrated steps and extends the 200 millisecc/cm step to at least 0.5 sec/cm.

Sweep Expand: X5 sweep expansion may be used on all ranges and expands fastest sweep to 1 μ sec/cm. Expansion is about the center of the crt and expanded sweep accuracy is $\pm 10\%$.

Synchronization: Automatic from 50 cps to 250 kc; internally from vertical deflection signals causing $\frac{1}{2}$ cm or more vertical deflection; from external signals at least 2.5 volts peak-to-peak, and from line voltage.

Trigger Point: Zero crossing, negative slope of external sync signals, zero crossing, positive or negative slope of vertical deflection signals. Front panel control overrides automatic and permits the trigger point to be set between -10 to $+10$ volts. Turning fully counterclockwise into auto restores automatic operation.

HORIZONTAL AMPLIFIER

Bandwidth: DC coupled: dc to 300 kc. AC coupled: 2 cps to 300 kc. Bandwidth is independent of attenuator setting.

Sensitivity: 0.1 volt/cm to 100 volts/cm. 3 calibrated steps, accurate within $\pm 5\%$, .1 v/cm, 1 v/cm, and 10 v/cm. Vernier permits continuous adjustment of sensitivity between steps and extends 10 v/cm step to at least 100 v/cm.

Input Impedance: 1 megohm, nominal, shunted by approximately 100 pf.

Phase Shift: Horizontal and vertical amplifiers have same phase characteristics within $\pm 2^\circ$ to 100 kc when verniers are in CAL.

GENERAL

Cathode Ray Tube: G203A (P1) internal graticule, mono-accelerator normally supplied; 2500-volt accelerating potential, P2, P7, and P11 phosphors are also available.

Internal Graticule: 10 cm x 10 cm marked in cm squares. Major horizontal and vertical axes have 2 mm subdivisions.

Intensity Modulated: Terminals on front panel. $+20$ volts to blank trace of normal intensity.

Dimensions: 16 $\frac{3}{4}$ in. wide, 7 $\frac{1}{2}$ in. high, 16 $\frac{3}{8}$ in. deep overall; hardware furnished for quick conversion to 7 in. x 19 in. rack mount.

Weight: Net 32 lbs.

Power: 115 or 230 volts $\pm 10\%$, 50 to 1000 cps.

Approximately 105 watts.

Options: 2. P2 CRT installed.

7. P7 CRT installed.

11. P11 CRT installed.

Price: Model 120B Oscilloscope: \$475.00 f.o.b. Palo Alto, Calif. Data subject to change without notice

TABLE I
GUIDE TO USE OF INTERNAL GRATICULE CRT
WITH -hp- OSCILLOSCOPES

Internal Graticule CRT Factory Installed (Specify Option 3)	-hp- OSCILLOSCOPE MODEL NO.							
	120A/AR	122A/AR	130B/BR	150A	160B/BR	170A/AR	185A	185B/BR
	Not available	Add \$30.00	Add \$30.00	Add \$30.00	Add \$30.00	Add \$30.00	Not available	Add \$30.00
Field Modification Kit (Includes new Cathode Ray Tube)	\$75.00	\$75.00	\$75.00	\$90.00	\$90.00	\$131.50	\$75.00	\$75.00

rounded peaks which help to diffuse reflections. With no filter or graticule in front of the crt, there are no air-to-glass surfaces to cause internal reflections and Newton rings. The surface of the disc will accept pencil or crayon marks for sketching reference waveforms or scales on the crt face and can be easily cleaned when the markings are no longer needed. This is in contrast to the conventional clear plastic graticule surface which is difficult to draw marks on and which scratches very easily. The bonding of the disc to the faceplate is such that the crt can implode without harm to the viewer. The resulting improved appearance of the trace is illustrated in Fig. 4.

A filter is not normally used with the new crt's. In applications where filtering is essential, a conventional filter can be placed in front of the crt. Anti-reflection properties, of course, are then sacrificed. Photography with the new crt's requires a new technique since the graticule cannot be illuminated with edge lighting. Entirely readable photographic reproductions of the graticule can be made by leaving the viewing port on the -hp- Model 196A oscilloscope camera about half open under typical ambient light conditions. For highest quality reproductions, a method has been developed in which the face of the crt is illuminated from a weak light source installed inside the camera. This light source is being prepared to be available in the form of a modification kit for the 196A camera. The photo-

graph in Fig. 4 demonstrates the results obtainable using the modified camera.

The internal graticule cathode ray tube is standard equipment on the new Model 120B oscilloscope described elsewhere in this issue. It is also available as a factory option or as a field modification kit on the oscilloscopes listed in Table I. An extra provision required in oscilloscopes having the internal graticule is a trace alignment coil. The coil fits around the crt, and current through the coil creates a magnetic field which is used to rotate the beam to exact alignment with the scale. This simple adjustment allows for initial factory alignment of the trace and makes it convenient to re-align the trace whenever the instrument is moved with respect to the earth's magnetic field or whenever other strong dc fields are present.

BURN-RESISTANT PHOSPHORS

The new internal graticule cathode ray tubes represent the beginning of the second phase of a program which started some time ago when -hp- began manufacturing cathode ray tubes. During the first phase, the major effort was expended in developing facilities and techniques for producing standard type crt's. Nevertheless, the first phase saw a number of significant improvements achieved in the performance of crt's.

New methods and careful process control have resulted in sharply reduced field failure rates. Experimentation in phosphor processing

has led to a new technique which greatly reduces the tendency of phosphors to burn. In -hp- manufactured crt's, even P7 phosphor, generally regarded as extremely sensitive to burning, will withstand normal usage with little danger of burning. In addition to burn resistance, the new technique has also resulted in a significant increase in brightness.

In -hp- crt's that operate at relatively high accelerating potentials, aluminizing is now used to enhance the brightness of most phosphor types. The aluminum film backing on the phosphor aids brightness by reflecting light emitted toward the inside of the crt. The conductive aluminum film also prevents a negative charge from building up on the screen. Brightness is thus further enhanced since electrons reach the screen at a higher velocity.

Brightness of 5 kv and 10 kv crt's has been improved still further by converting to P31, a new, extremely efficient phosphor, with a spectral response closely matched to the eye. In the Models 150A and 160B oscilloscopes, aluminized P31 is now supplied in place of non-aluminized P2, with an increase in visual brightness of approximately 250%. In all -hp- oscilloscopes, dual purpose P2 phosphor as well as long persistence P7 and photographic P11 are available as standard options. Other phosphor types can be supplied on request. — *Bertrand W. Squier, Jr.*